

CUSTOMER PART No.

CUSTOMER

CAN ART STD.

DIE No.

EH05452

DESCRIPTION

1 1/2" x 1 1/2" x 0.188" THK. SQ. TUBE

PROPOSAL No.

H-3287

NOTE: BREAK ALL CORNERS WITH 0.015" (.38 MM) RADIUS UNLESS OTHERWISE SPECIFIED. STANDARD TOLERANCES TO APPLY UNLESS OTHERWISE SPECIFIED.

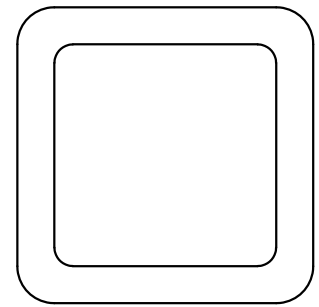
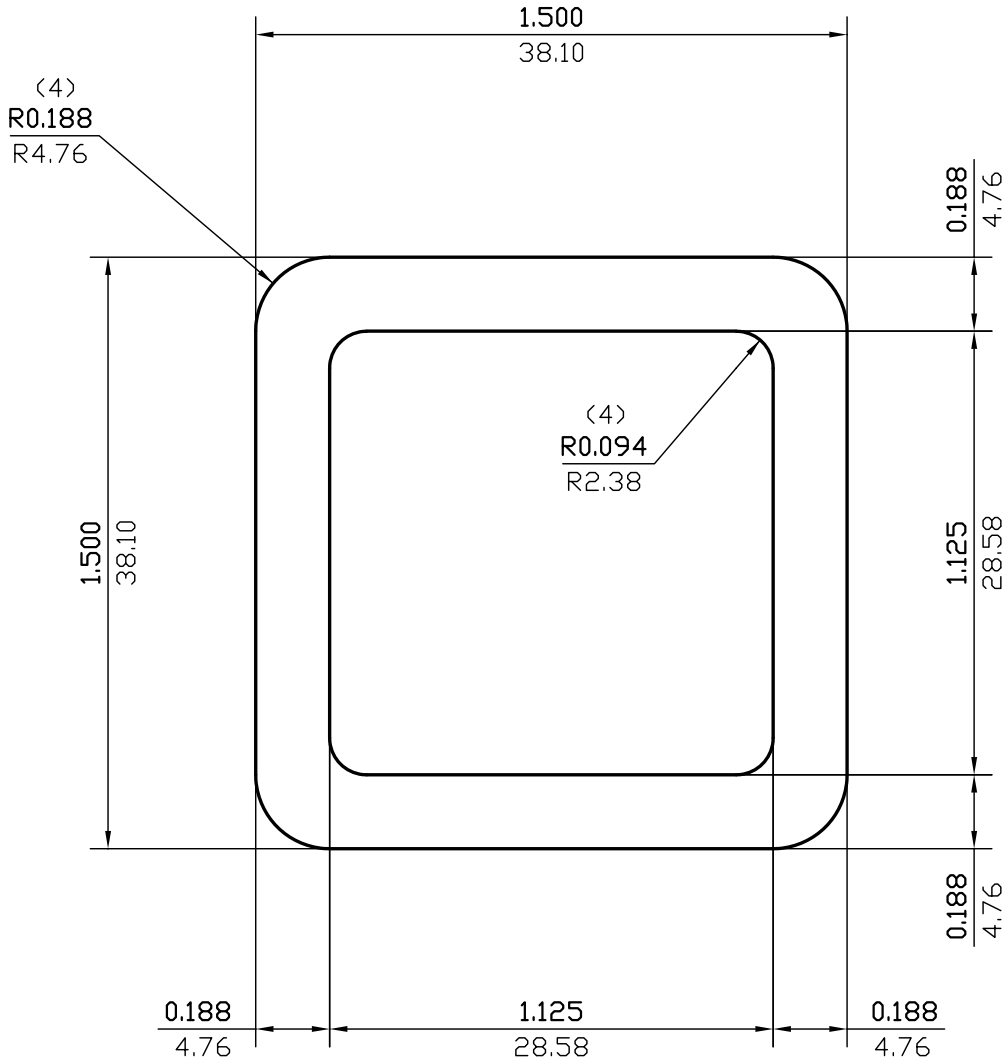

ACTUAL SIZE

WALL THICKNESS 0.188 (4.76) EXCEPT AS SHOWN

DATE	REV	DESCRIPTION	BY		
03/13/23	2	REMOVED ALLOY	JASON		
08/06/99	1	REDRAWN	P.M.		
EST.AREA	0.962	IN. ²	EST.AREA	620	MM. ²
EST.WT.	1.135	LBS/FT.	EST.WT.	1.689	KG/M.
EST.PER.	10.017	IN.	EST.PER.	254.4	MM.
OUT PER.	5.678	IN.	OUT PER.	144.2	MM.
C.C.D.	1.966	IN.	C.C.D.	50	MM.
FACTOR	9	FINISH	M/F	ALLOY & TEMP.	
CKD BY		SCALE	2:1	DWN BY	C.P. DATE 06/07/94

CAN ART

ALUMINUM EXTRUSION INC.

85 PARKSHORE DRIVE
BRAMPTON, ONT L6T 5M1
TEL. NO. (905) 791-1464
FAX NO. (905) 791-9151
E-MAIL: canart@canart.com

THIS DRAWING IS NOT NECESSARILY A COPY OF YOUR ORIGINAL. PLEASE APPROVE DIMENSIONS AND TOLERANCES INDICATED. CAN ART ASSUMES NO RESPONSIBILITY EITHER TECHNICAL OR LEGAL FOR HAVING THIS SHAPE MADE. THE CUSTOMER AGREES TO FULLY PROTECT CAN ART ALUMINUM FROM CLAIMS OF OTHERS RESULTING FROM THIS SHAPE.

SIGNED: _____ DATE: _____